

Tools & Material

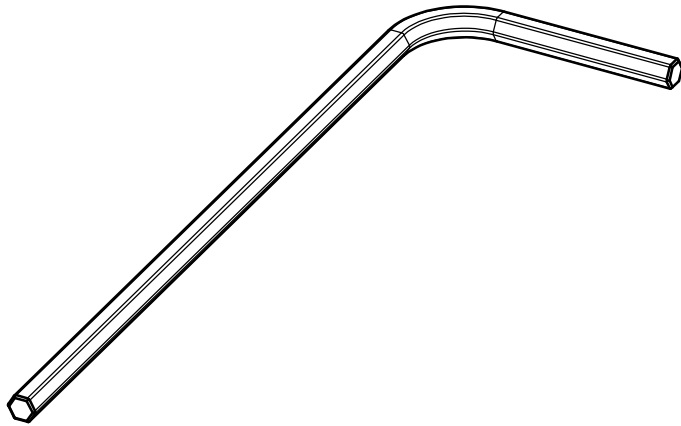

Hex 2,5 mm

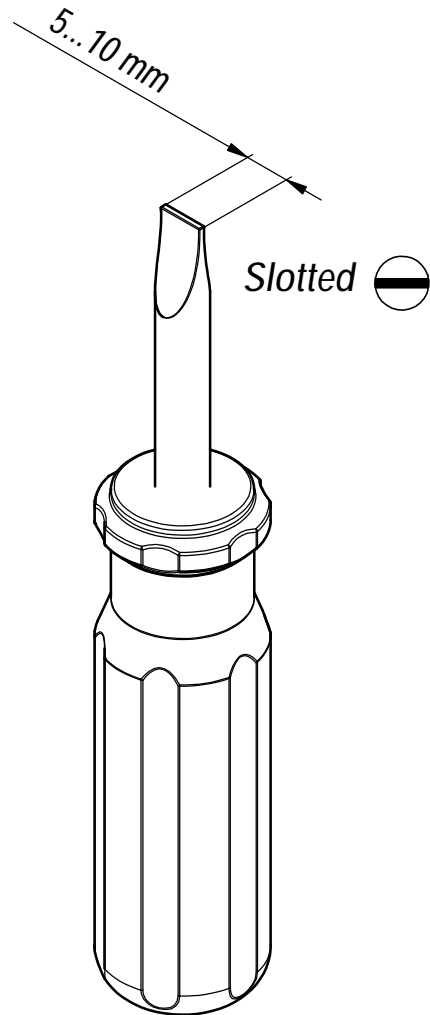

Screwdriver

A

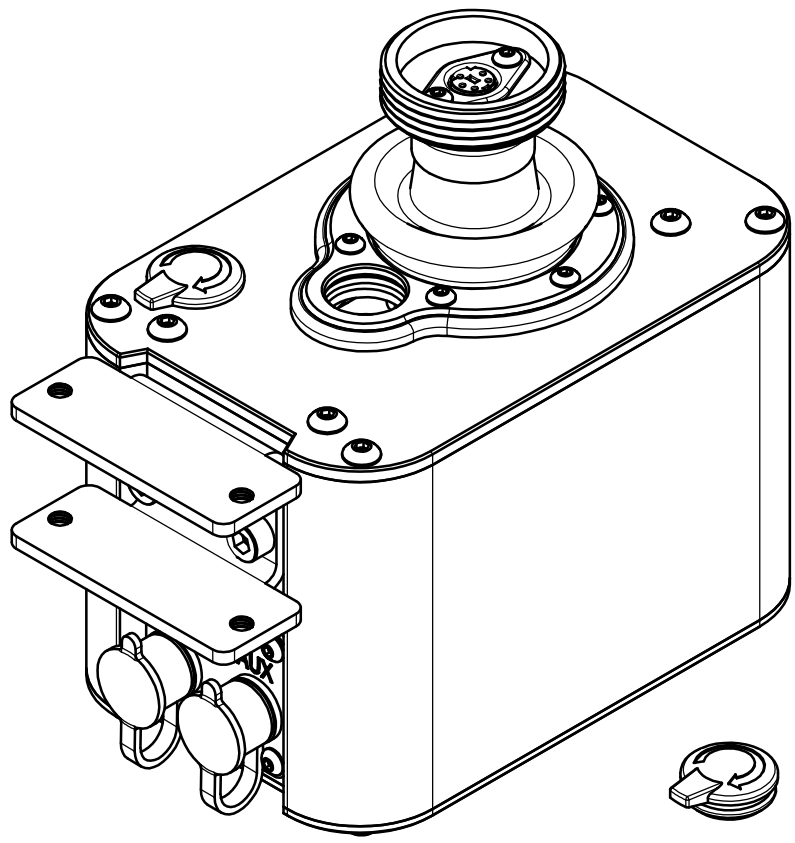
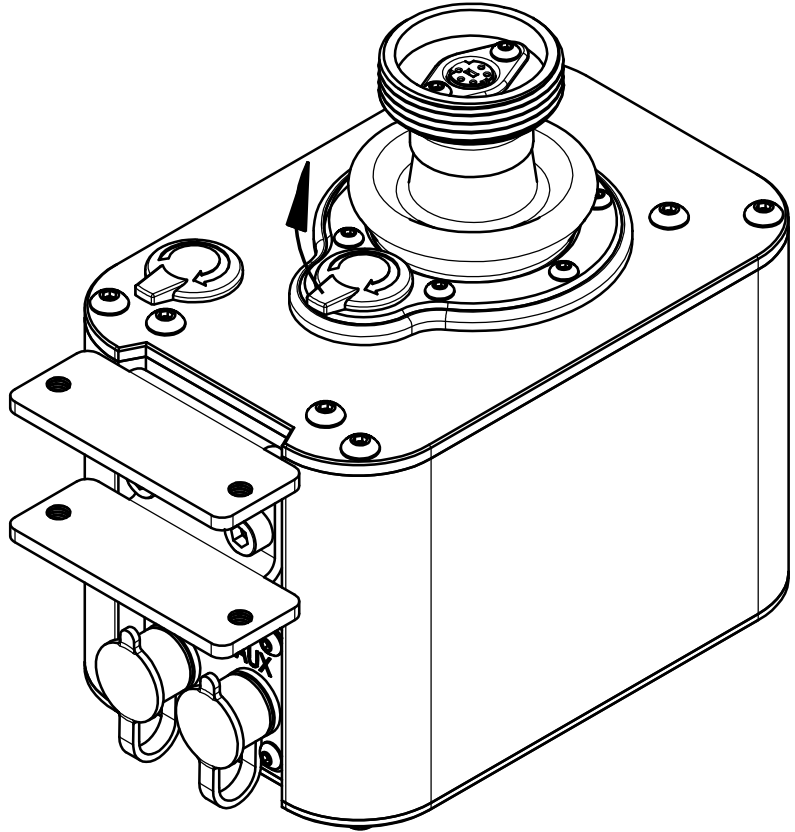

B

28...30 full turns

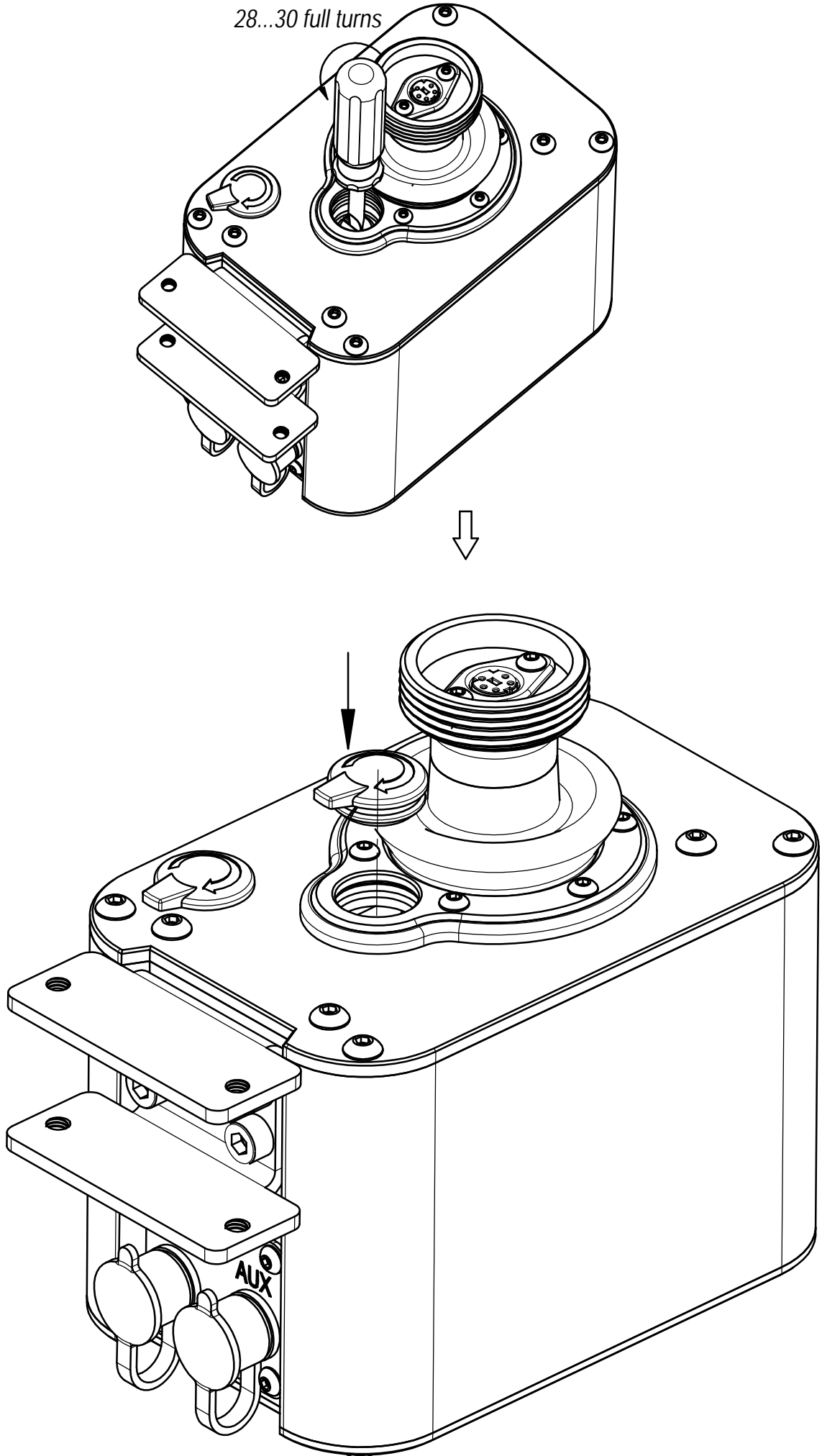

C

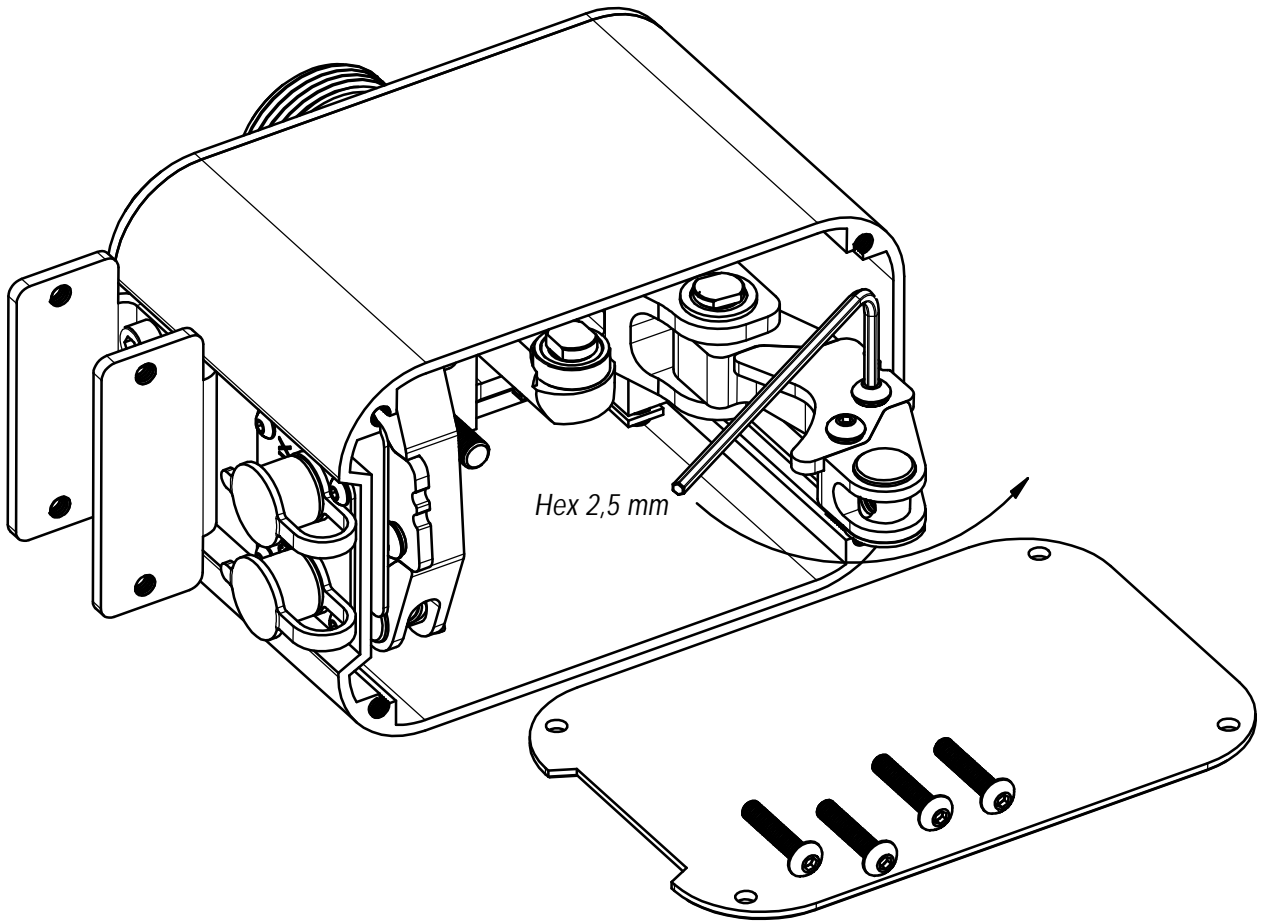
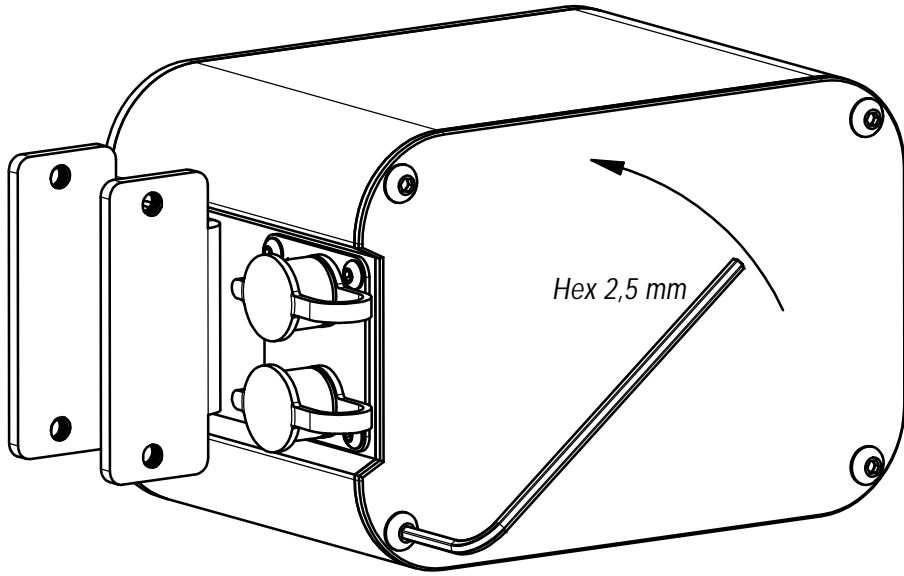

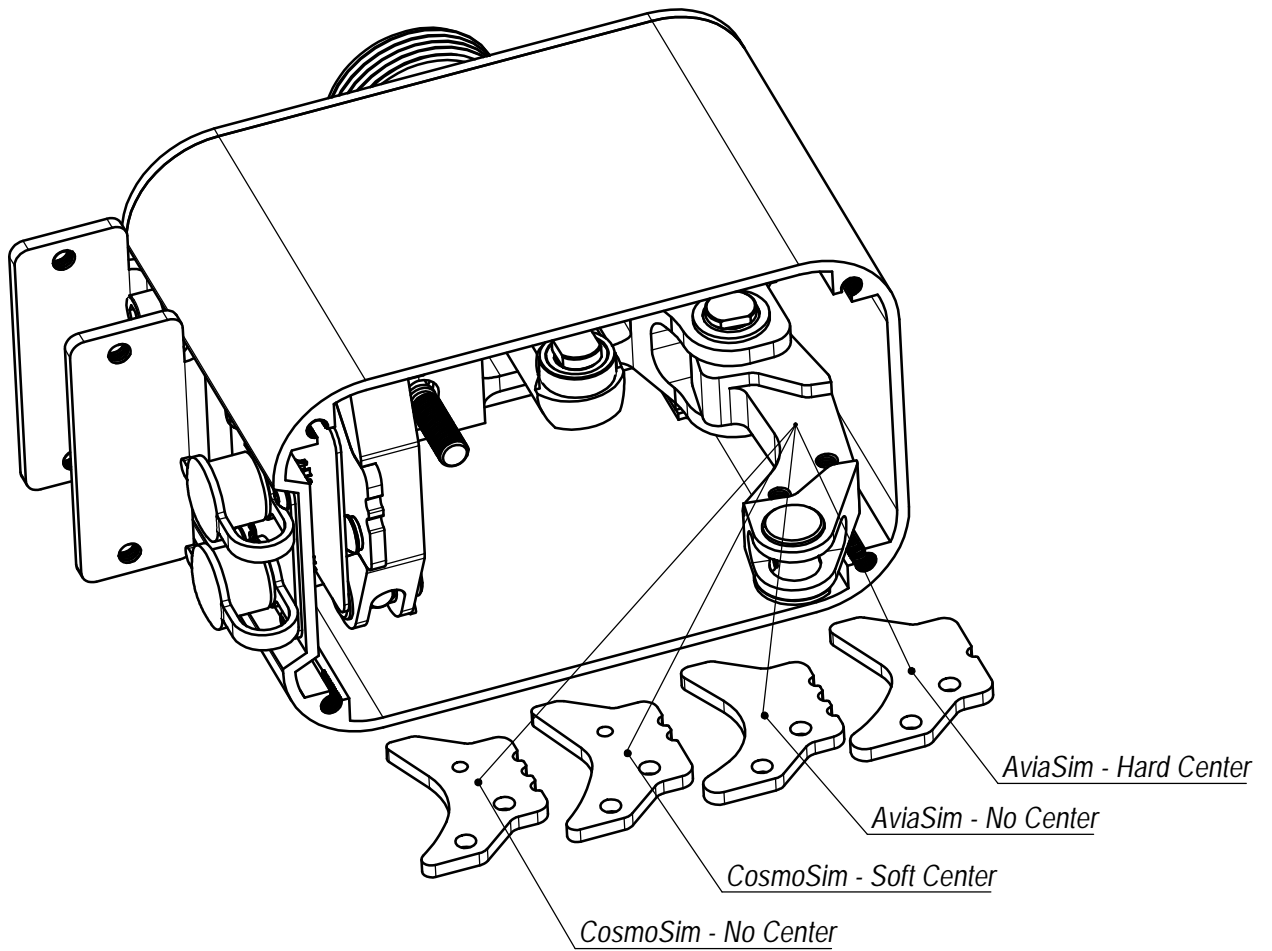
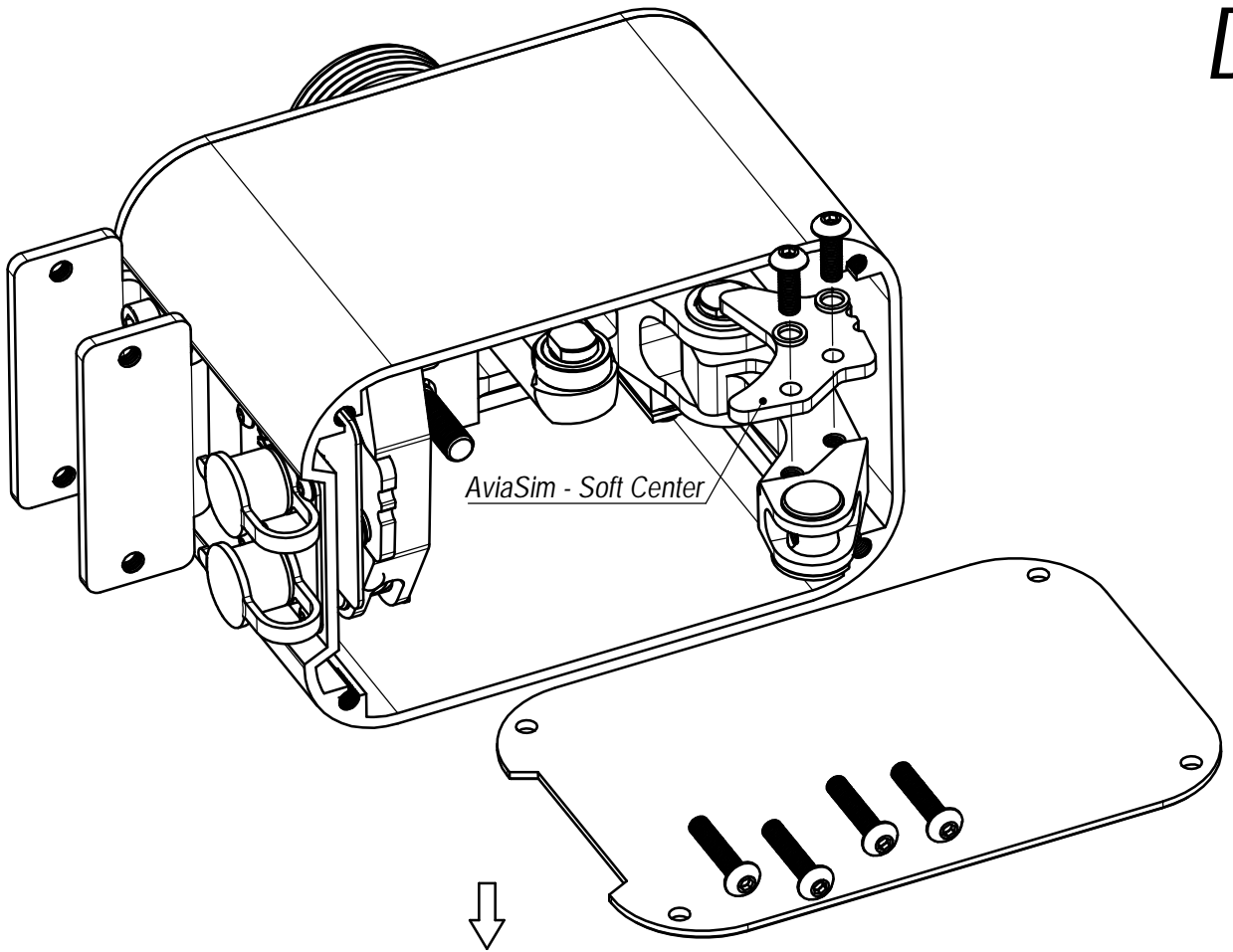

E

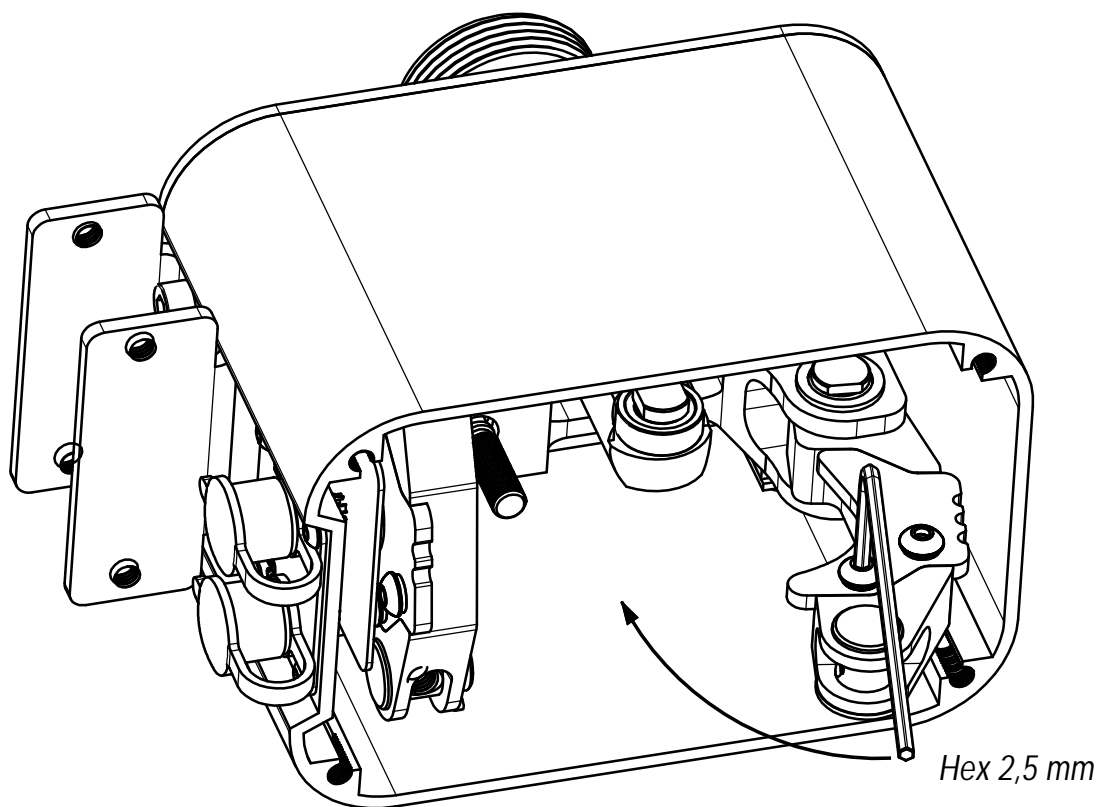
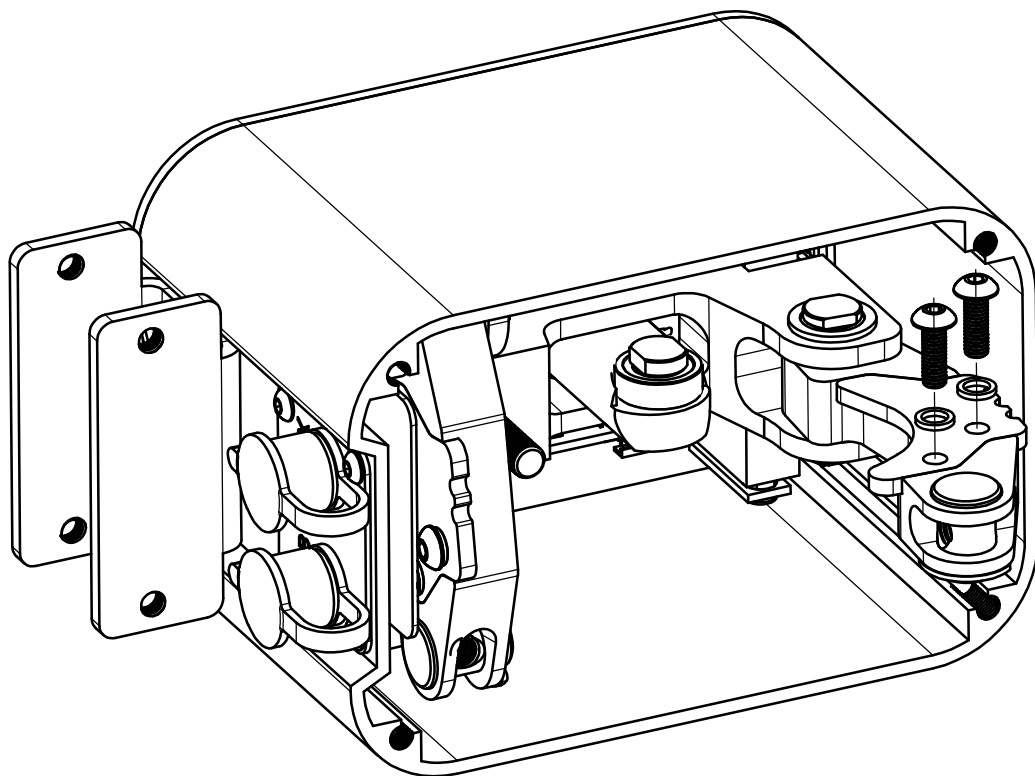

F

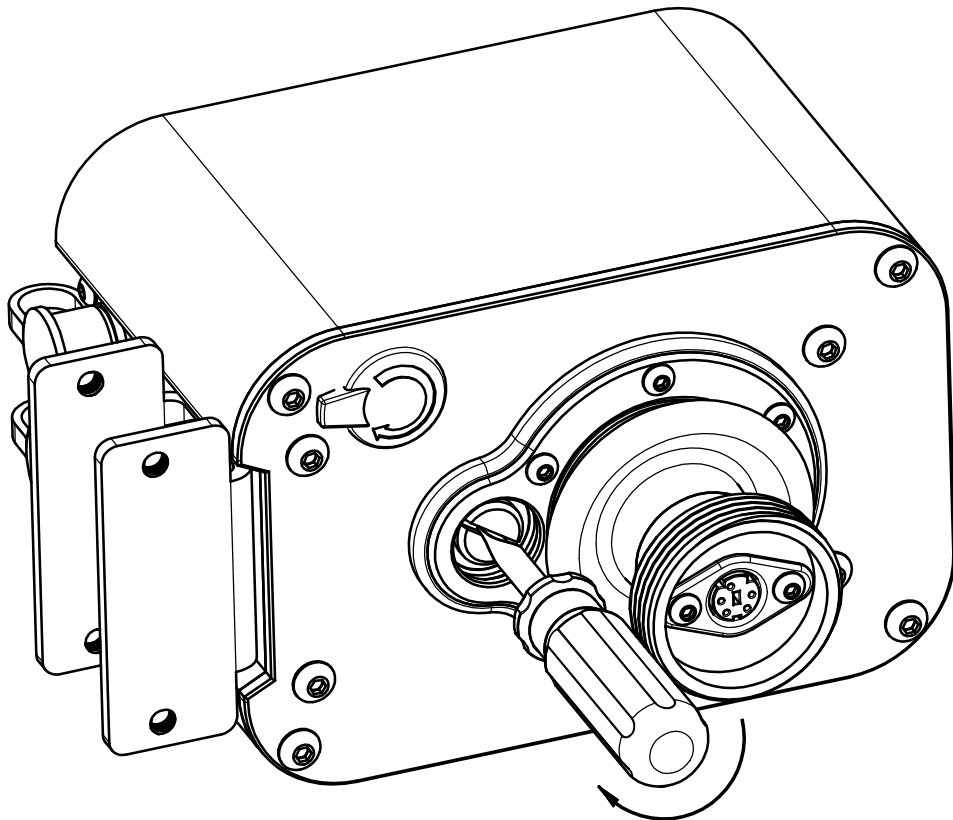
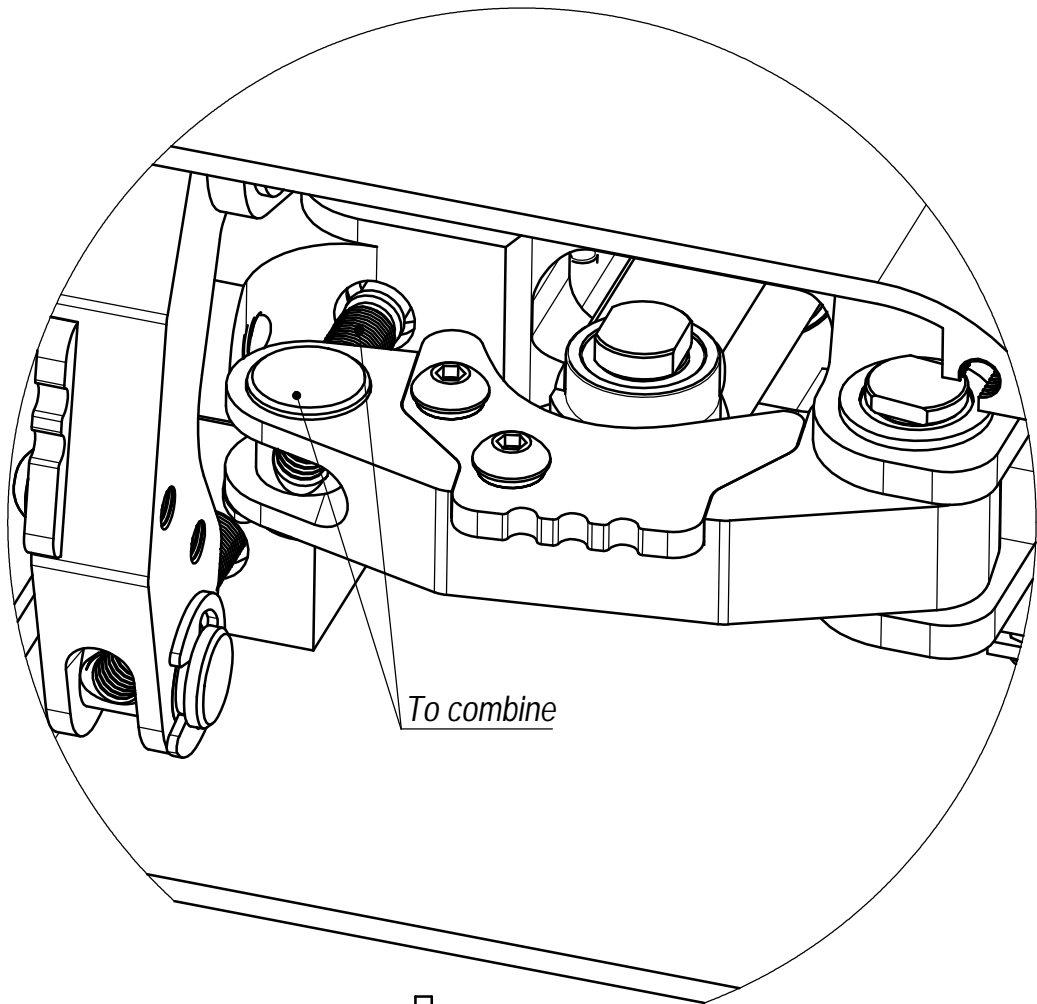

*Wrap until it stops.
Then turn counterclockwise by 6 ... 8 full turns.*

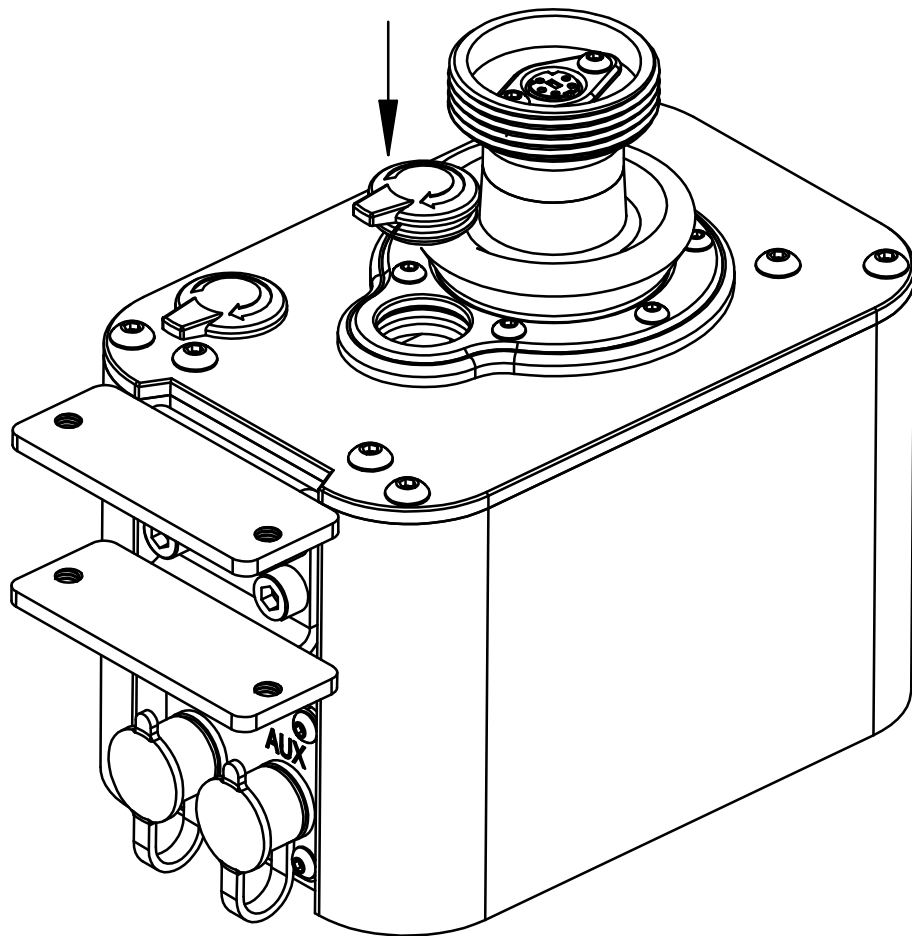
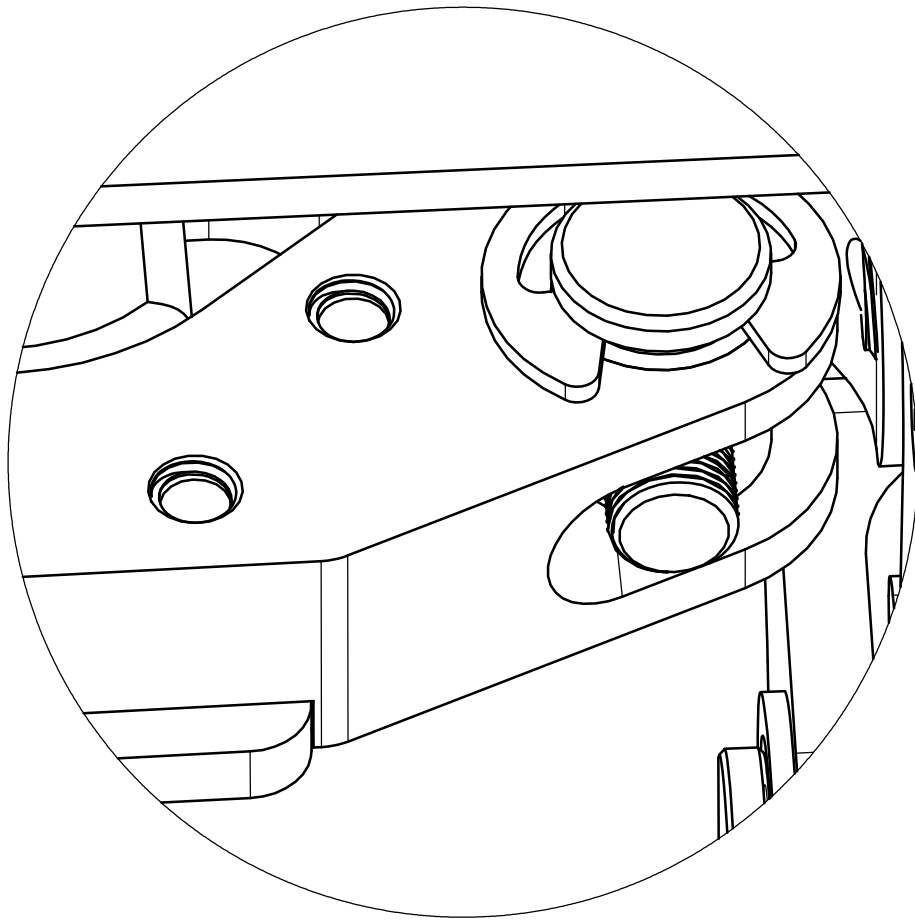

The procedure for replacing the cam on the roll axis is the same as on the pitch axis.

H

